

Terwin Instruments Ltd.



Winterbeck Industrial Estate, Orston Lane,
BOTTESFORD, Nottinghamshire
NG13 0AU
ENGLAND

Tel: +44 (0) 1949 84 2000

Fax: +44 (0) 1949 84 2004

Web site: www.terwin.com

E-mail: info@terwin.com

Environmentally Friendly Stainless Steel Construction. Contains NO Liquid Fills At All.
Rugged Di-Hard Abrasion & Corrosion Resistant Diaphragm
Suitable For Temperature Upto 450°C / 842°F
Temperature Specifications: Zero: 0.01% F.R.O./°C Span: 0.01% F.R.O./°C
Sensing Diaphragm Typically At Least 4 X Thicker Than Our Competitors
Calibration & Connectors to Replace All Competitors Models.
Integral "J" I/C or "K" C/A Thermocouple Available.
Accuracy: Within 0.5% F.R.O. (typically 0.25%).
Available With Four Different Stem Lengths:
3.64" (92.5mm), 6.0" (152.4mm)
9.0" (228.6mm) & 12.0" (305.0mm)
Standard Thread Size: 1/2"-20UNF-2A



Environmentally Friendly - No Fill Materials

Model 2076 Extrusion Pressure Transducer
TERWIN - Manufacturing Transducers That Perform Since 1983
Accept No Substitutes

2000 SERIES PRESSURE / TEMPERATURE TRANSDUCER

INSTALLATION AND CALIBRATION INSTRUCTIONS

IMPORTANT NOTICE!

*The 2000 series pressure / temperature transducers are **precision instruments** and it is **important** to follow the instructions below to avoid unnecessary damage.*

HANDLING

The transducers should be handled with great care. They should not be dropped and the front diaphragm should be prevented from coming into contact with sharp objects. Under no circumstances should the diaphragm be cleaned with a wire brush or abrasive cleaners. If the transducers require cleaning, use only a clean cloth when the transducer is hot and at around the same temperature as the material which was previously being processed. Additionally, always ensure that before removing a transducer from an extruder, the processed material is still at its working temperature. If the material being extruded has become cold, this could lead to the diaphragm being damaged when the transducer is removed.

UNDER NO CIRCUMSTANCES MUST THE TRANSDUCER BE REMOVED FROM THE EXTRUDER WHILST UNDER PRESSURE!

BEFORE INSTALLATION

Always ensure that the mounting hole conforms to the required dimensions that are shown on the reverse of this leaflet, and that it is clean and entirely free of old processed material that may damage the transducers sensitive diaphragm.

INSTALLATION

Lubricate the threads of the transducer before each installation with Dow Corning Molycote G or a similar product. Screw the transducer into the extruder and torque to 20ft lbs. maximum - 10ft lbs. minimum. DO NOT over torque as this may lead to the transducer being damaged beyond repair.

RECOMMENDED PORT DIMENSIONS

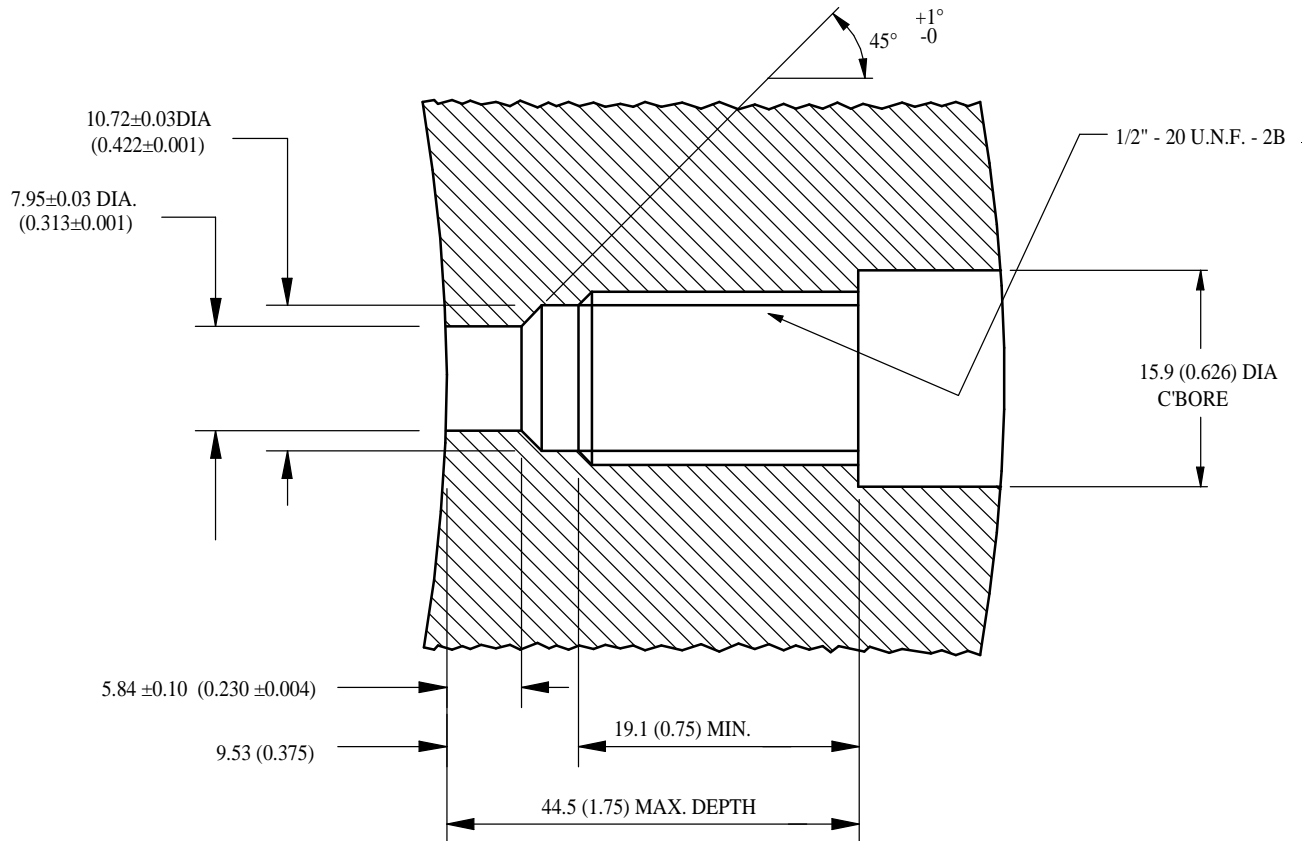

ELECTRICAL CONNECTIONS

Please refer to the calibration data sheet which is sent out with each 1000 / 2000 & 2200 series pressure transducer, full electrical connections / specifications are detailed on this.

CALIBRATION

Note: All adjustments are to be made at zero pressure.

- 1) Ensure that the pressure transducer is at working temperature and power has been applied to the measuring instrument.
- 2) Adjust the ZERO screw on the measuring instrument until a true zero reading is achieved. (For Auto zero and calibration. instruments, see their instruction manuals.)
- 3) Press the "SPAN" or "CALIBRATION" switch on the measuring instrument and adjust the SPAN or CAL screw so the instrument display matches the calibration figure that is printed on the pressure transducer. This value is stated in both percentage of full-scale range and also in psi, bar etc., if a 10,000psi transducer has a calibration value of 80%, this calibration will also be expressed as 8,000psi.
- 4) Re-check the zero reading and adjust again if necessary and then repeat the Span/CAL adjustment as detailed above in section 3).

CAUTION:-

DO NOT make ANY adjustments when there is pressure on the transducer. This could cause the pressure reading to be low, resulting in the machine being over pressurised.

COLD STARTS

Always ensure that the processed product has reached the correct extrusion temperature before the screw is run. Failure to adhere to this instruction may lead to the transducer sensing diaphragm being damaged.

SERVICING

If repairs are required, the pressure / temperature transducer should be adequately packed to prevent damage, with a note describing the observed problems and shipped pre-paid to your nearest Terwin representative or:-

The Service Department
Terwin Instruments Ltd
Winterbeck Industrial Estate
Orston Lane
BOTTESFORD
Nottinghamshire
NG13 0AU
ENGLAND

WARRANTY

Terwin Instruments Limited warrants equipment of its manufacture against defects in materials and workmanship for a period of one year from date of despatch. *Terwin Instruments Limited's* obligation under warranty is expressly limited to the repairing or replacing at its factory, or at any authorised representatives repair station, providing that:

- (a) *Terwin Instruments Limited* is promptly notified by the buyer upon his/her discovery of a defect.
- (b) The defective equipment is returned, with transportation charges pre-paid by the buyer.
- (c) Providing the defective unit has not been damaged by negligence, improper use or unauthorised repair or alteration.

THIS WARRANTY IS IN LIEU OF ALL OTHER WARRANTIES, EXPRESSED OR IMPLIED, INCLUDING THE IMPLIED WARRANTY OF FITNESS FOR A PARTICULAR PURPOSE WHETHER TO THE ORIGINAL PURCHASER OR TO ANY OTHER PERSON. TERWIN INSTRUMENTS LIMITED SHALL NOT BE LIABLE FOR CONSEQUENTIAL DAMAGE OF ANY KIND.

The aforementioned provisions do not extend the original warranty period of any article that has been either repaired or replaced by *Terwin Instruments Limited*.

Terwin Instruments Limited shall not be bound by any terms, conditions, representations or warranties, expressed or implied, which are not stated herein.

Terwin Instruments Ltd



**Manufacturers Of Industrial Pressure / Temperature
Sensors & Instrumentation**

➤ Try This Product To Help Installation Problems:

Terwin Pressure Transducer Simulator



Length 90mm x Width 55mm x Depth 40mm
Model Shown: Simulator D6/D8 (Also available with G or D9 connectors)

Description:

The Terwin **pressure transducer simulator** has been designed as a service aid to engineers that are involved in the extrusion of plastics, rubber and food.

Should a fault occur on an extrusion pressure monitoring / control system, the simulator will enable the plant engineer to check both the cable assembly and associated indicator / controller / signal conditioner by simply plugging the transducer cable assembly into the simulator and checking all the functions with the eleven point rotary switch.

This simple device may avoid the unnecessary removal of the pressure transducer from the machine, thus saving valuable down time.

SPECIFICATIONS

Accuracy	±0.25%
Full Scale Output	Nominal 3mV/V
Configuration	350 ohm Wheatstone bridge
Input Resistance	350 ohm ±0.5%
Output Resistance	350 ohm ±0.5%
Range	0-100% of F.R.O. in 10% steps
Zero Balance	±0.25% of F.R.O.
Excitation	5 – 12V D.C.